

**United States Court of Appeals  
for the Federal Circuit**

---

**FORUM US, INC., A DELAWARE CORPORATION,**  
*Plaintiff-Appellee*

v.

**FLOW VALVE, LLC, AN OKLAHOMA LIMITED  
LIABILITY COMPANY,**  
*Defendant-Appellant*

---

2018-1765

---

Appeal from the United States District Court for the  
Western District of Oklahoma in No. 5:17-cv-00495-F, Sen-  
ior Judge Stephen P. Friot.

---

Decided: June 17, 2019

---

KEITH JAASMA, Ewing & Jones, PLLC, Houston, TX, ar-  
gued for plaintiff-appellee. Also represented by HARVEY D.  
ELLIS, JR., DAVID M. SULLIVAN, Crowe & Dunlevy, PC, Ok-  
lahoma City, OK.

GARY PETERSON, Tomlinson McKinstry, PC, Oklahoma  
City, OK, argued for defendant-appellant. Also repre-  
sented by ROSS N. CHAFFIN, KELLY J. KRESS, ROBERT D.  
TOMLINSON.

---

Before REYNA, SCHALL, and HUGHES, *Circuit Judges*.

REYNA, *Circuit Judge*.

Flow Valve, LLC appeals from the U.S. District Court for the Western District of Oklahoma’s grant of summary judgment of invalidity of its reissue patent. The original patent does not disclose the invention claimed in the reissue patent. The reissue claims therefore do not comply with the original patent requirement of 35 U.S.C. § 251 as a matter of law. We affirm.

## BACKGROUND

### I. The Patent-in-Suit

Flow Valve owns U.S. Patent No. RE45,878 (“the Reissue patent”), entitled “Workpiece Supporting Assembly.” The Reissue patent is a reissue of U.S. Patent No. 8,215,213 (“the ’213 patent”). During prosecution of the Reissue patent, the patentees added seven claims—claims 14 through 20—but made no changes to the written description or drawings of the original ’213 patent.<sup>1</sup>

The Reissue patent relates to supporting assemblies, i.e., fixtures, for holding workpieces during machining. The workpieces disclosed in the patent are machined pipe fittings, such as those used in the oil and gas industry. Such fittings attach to other pipe sections by means of threaded connections where one or more ends of the fitting require machining on a turning machine to form threads or seat surfaces. Reissue patent col. 1 ll. 20–27. A turning machine, such as a lathe, rotates the workpiece while stationary tools perform various operations on the workpiece, such as cutting or sanding, as the workpiece rotates. *See id.* col. 1 ll. 29–37. Machinists often make and use fixtures

---

<sup>1</sup> The ’213 and Reissue patents share identical written descriptions and drawings. We therefore refer to the Reissue patent unless otherwise noted.

that utilize arbors to hold the workpiece while it rotates on the turning machine, and it is advantageous to have a multi-purpose fixture capable of holding a workpiece in multiple orientations to expedite machining by minimizing setup time. *See id.* col. 1 ll. 36–58.

The written description and drawings disclose only embodiments with arbors. The following figures illustrate the placement of arbors in a machining fixture for holding the pipe joint as disclosed in the Reissue patent.

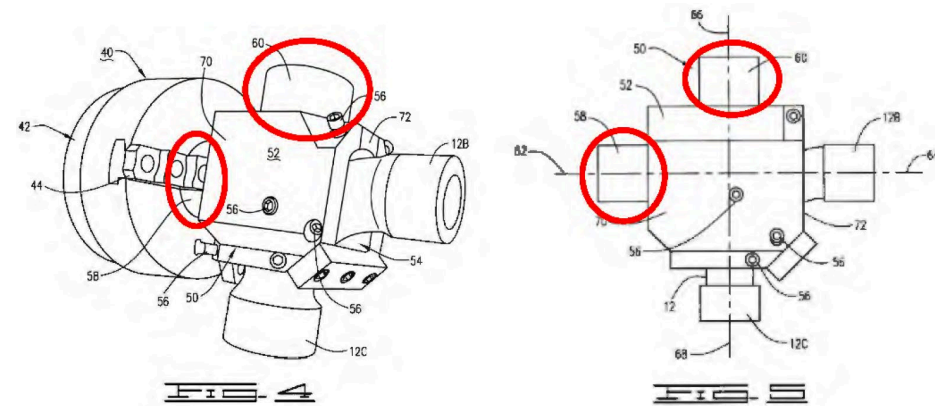

Reissue patent Figs. 4 & 5 (annotations added by Appellee). The written description discloses a first and a second arbor as central to the fixture design:

[T]he body member 52 has a *first arbor 58* and a *second arbor 60* supported to extend from the body member 52. The *first arbor 58* is positioned so that the longitudinal axis 62 thereof is coincident with the datum or central axis 64 of the extending elbow end 12B so that, when workpiece machining implement 40 rotates the chuck 42, the *first arbor 58* is rotated about its longitudinal axis 62, the body member 52 will rotate the elbow end 12B about the datum axis 64 thereof.

In like manner, the *second arbor 60* is positioned so that the longitudinal axis 66 thereof is

coincident with the datum or central axis 68 of the extending elbow end 12C.

Reissue patent col. 3 ll. 11–22 (emphases added). The written description further explains that “the multiple arbors of the workpiece supporting assembly provides [*sic*] means for machining the ends of the unfinished elbow member 12 by a single setup and only a change from one arbor to one of the other arbors allows rapid and accurate machining of the workpiece.” *Id.* col. 3 ll. 42–46.

In the Reissue patent, the patentees broadened the claims to include embodiments of fixtures that do not use arbors by writing new claims without the arbor limitations. Claim 1 of the '213 patent is representative of the original claims:

1. A workpiece machining implement comprising:

a workpiece supporting assembly comprising:

a body member having an internal workpiece channel, the body member having a plurality of body openings communicating with the internal workpiece channel;

means supported by the body member for positioning a workpiece in the internal workpiece channel so that extending workpiece portions of the workpiece extend from selected ones of the body openings;

a *plurality of arbors* supported by the body member, *each arbor* having an axis coincident with a datum axis of one of the extending workpiece portions; and

means for rotating the workpiece supporting assembly about the axis of a selected *one of the arbors*.

'213 patent col. 3 l. 52–col. 4 l. 5 (emphases added). Claim 14 is representative of the claims added (14–20) to the Re-issue patent:

14. A workpiece supporting assembly for securing an elbow during a machining process that is performed on the elbow by operation of a workpiece machining implement, the workpiece supporting assembly comprising:

a body having an internal surface defining a channel, the internal surface sized to receive a medial portion of the elbow when the elbow is operably disposed in the channel; and

a support that is selectively positionable to secure the elbow in the workpiece supporting assembly, the body pivotable to a first pivoted position, the body sized so that a first end of the elbow extends from the channel and beyond the body so the first end of the elbow is presentable to the workpiece machining implement for performing the machining process, the body pivotable to a second position and sized so that a second end of the elbow extends from the channel beyond the body so the second end of the elbow is presentable to the workpiece machining implement for performing the machining process.

Reissue patent col. 4 l. 64–col. 5 l. 15.

## II. The Procedural History

On April 28, 2017, Forum US, Inc. filed a declaratory judgment action seeking a declaration of invalidity of the Reissue patent. Forum contended that the added reissue claims were invalid because they did not comply with the original patent requirement under 35 U.S.C. § 251. Forum moved for summary judgment on the basis that the reissue claims improperly broadened the original patent claims by omitting the arbor limitations in violation of the original patent requirement because the patent did not disclose an invention without arbors. J.A. 101–15.

In opposition, Flow Valve argued that a person of ordinary skill in the art would understand that the patent disclosed multiple inventions, consisting of embodiments with and without arbors. Flow Valve supported its argument with an expert declaration from Terry Iafrate, an experienced machinist.

The district court granted summary judgment in favor of Forum on the basis that the written description and drawings of the Reissue patent do not “explicitly and unequivocally” indicate the invention claimed in the reissue claims. J.A. 12–13 (citing *Antares Pharma, Inc. v. Medac Pharma Inc.*, 771 F.3d 1354 (Fed. Cir. 2014)). The district court found that the Iafrate declaration did not create a genuine issue of material fact because “no matter what a person of ordinary skill would recognize, the specification of the original patent must clearly and unequivocally disclose the newly claimed invention in order to satisfy the original patent rule.” *Id.*

Flow Valve appeals. We have jurisdiction under 28 U.S.C. § 1295(a)(1).

## DISCUSSION

This court reviews the district court’s grant of summary judgment de novo. *Conroy v. Reebok Int’l, Ltd.*, 14 F.3d 1570, 1575 (Fed. Cir. 1994). In determining whether

the district court properly granted summary judgment, we view the evidence in the light most favorable to the non-moving party. *Israel Bio-Eng'g Project v. Amgen, Inc.*, 475 F.3d 1256, 1263 (Fed. Cir. 2007).

Whether new claims in a reissue patent comply with 35 U.S.C. § 251 is a question of law that we review de novo. *AIA Eng'g Ltd. v. Magotteaux Int'l S/A*, 657 F.3d 1264, 1271 (Fed. Cir. 2011). The legal conclusion regarding § 251 compliance, however, can involve underlying questions of fact. *Hester Indus., Inc. v. Stein, Inc.*, 142 F.3d 1472, 1479 (Fed. Cir. 1998). Although the court must determine whether the original and reissue patents are for the same invention, the court may consider expert “evidence to ascertain the meaning of a technical or scientific term or term of art so that the court may be aided in understanding not what the instruments mean but what they actually say.” *U.S. Indus. Chems., Inc. v. Carbide & Carbon Chems. Corp.*, 315 U.S. 668, 678 (1942).

In this case we must determine whether the new claims in the Reissue patent comply with the original patent requirement. We hold that they do not.

We begin our analysis with the language of the statute. Section 251(a) provides:

*Whenever any patent is, through error, deemed wholly or partly inoperative or invalid, by reason of a defective specification or drawing, or by reason of the patentee claiming more or less than he had a right to claim in the patent, the Director shall, on the surrender of such patent and the payment of the fee required by law, reissue the patent for the invention disclosed in the original patent, and in accordance with a new and amended application, for the unexpired part of the term of the original patent. No new matter shall be introduced into the application for reissue.*

35 U.S.C. § 251(a) (emphases added).

It is well settled that for broadening reissue claims, “it is not enough that an invention might have been claimed in the original patent because it was suggested or indicated in the specification.” *Indus. Chems.*, 315 U.S. at 676 (interpreting 35 U.S.C. § 64 (1934)). The Supreme Court described this standard in nearly identical language almost fifty years before *Industrial Chemicals*. See *Corbin Cabinet Lock Co. v. Eagle Lock Co.*, 150 U.S. 38, 42–43 (1893) (“[T]o warrant new and broader claims in a reissue, such claims must not be merely suggested or indicated in the original specification, drawings, or models, but it must further appear from the original patent that they constitute parts or portions of the invention, which were intended or sought to be covered or secured by such original patent.”). Congress codified this long-standing requirement, which became known as the “same invention” requirement. *Antares*, 771 F.3d at 1359–60 (quoting 35 U.S.C. § 64 (1946)); see, e.g., Section 53, Patent Act of 1870, 16 Stat. 198 (1870) (“[T]he commissioner shall . . . cause a new patent for the same invention . . . to be issued to the patentee.”).

With the passage of the 1952 Patent Act, Congress revised the statutory language from “the same invention” to “the original patent.” *Antares*, 771 F.3d at 1360; 35 U.S.C. § 251 (1952). Despite this revision, case law has not suggested that the 1952 Patent Act’s revised statutory language substantively changed “the ‘same invention’ requirement or that the standard of *Industrial Chemicals* has in any way been altered by the legislative changes.” *Antares*, 771 F.3d at 1360–61.

Thus, for broadening reissue claims, the specification of the original patent must do more than merely suggest or indicate the invention recited in reissue claims; “[i]t must appear *from the face of the instrument* that what is covered by the reissue was intended to have been covered and secured by the original.” *Indus. Chems.*, 315 U.S. at 676



(emphasis added). Stated differently, the original patent “must clearly and unequivocally disclose the newly claimed invention as a separate invention.” *Antares*, 771 F.3d at 1362. We apply the standard set forth in *Industrial Chemicals* and *Antares* to this case and hold that the reissue claims are invalid.

Flow Valve does not dispute that the face of the original ’213 patent does not disclose an arbor-less embodiment of the invention. Further, the abstract and the summary of the invention both describe a plurality of arbors, indicating that the only disclosed invention includes arbors.

Instead, Flow Valve argues that a person of ordinary skill in the art would understand from the specification that arbors were an optional feature of the disclosed invention. Appellant Br. 16. In support of this argument, Flow Valve relies on the Iafrate declaration, which states that “a worker of ordinary skill would understand that not every fixture disclosed in the patent requires a ‘plurality of arbors’” and that “the arbors are an optional feature.” J.A. 181–82 ¶¶ 16, 19. Mr. Iafrate bases his opinion on passages in the specification that refer generally to “machining” as opposed to a “turning machine,” i.e., a lathe, and the statement in the specification that “it will be understood that numerous changes may be made which will readily suggest themselves to those skilled in the art which are encompassed within the spirit of the invention disclosed.” J.A. 182–83 ¶¶ 20–23 (citing Reissue patent col. 1 ll. 13–16, 41–44; *id.* col. 3 ll. 53–60).

We conclude that the Iafrate declaration, when viewed in the light most favorable to Flow Valve, does not raise a genuine dispute of material fact. The Iafrate declaration does not aid the court in understanding what the “instruments . . . actually say,” but instead asserts what a person of ordinary skill in the art would purportedly understand in the absence of the disclosure of an arbor-less embodiment. *See Indus. Chems.*, 315 U.S. at 678. Indeed,

nowhere do the written description or drawings disclose that arbors are an optional feature of the invention. Even if a person of ordinary skill in the art would understand that the newly claimed, arbor-less invention would be possible, that is insufficient to comply with the standard set forth in *Industrial Chemicals* and *Antares*.

The few references in the written description to machining in general do not refer to or disclose specific embodiments, and the boilerplate language that modifications can be made to the original disclosed invention does not even suggest an arbor-less embodiment of the disclosed invention. See *Indus. Chems.*, 315 U.S. at 676. Nor do these passages “clearly and unequivocally” disclose such an embodiment. See *Antares*, 771 F.3d at 1362. Thus, the reissue claims do not comply with the standard set forth in *Industrial Chemicals* and *Antares* as a matter of law.

*In re Amos* does not set forth a different standard or dictate a different outcome in this case. 953 F.2d 613 (Fed. Cir. 1991). The patentees in *Amos* sought a reissue patent to claim “a set of rollers mounted to hold down a workpiece . . . whereupon the rollers lift away.” *Id.* at 614. The reissue claims recited use of a computer to control the electronic lifting of the rollers. *Id.* The original patent explicitly disclosed that the rollers can be “raised either mechanically by the roller cams or electronically by the computer controlling [a] router.” *Id.* The original patent disclosed these two alternatives for raising the rollers, but the original claims did not recite the alternative of computer control. *Id.* Although the Patent Office concluded that the original patent disclosed the invention in the reissue claims, it denied the reissue application based on the lack of an “intent to claim” the new subject matter. We reversed, holding that the absence of an “intent to claim” was by itself an insufficient basis to deny the application and that instead, the “essential inquiry under the ‘original patent’ clause of § 251 . . . is whether one skilled in the art, reading the specification, would identify the subject matter

of the new claims as invented and *disclosed* by the patentees.” *Id.* at 618 (emphasis added); *see also Antares*, 771 F.3d at 1362. Such a disclosure of the subject matter claimed by the broadening reissue claims,<sup>2</sup> like the computer-controlled rollers disclosed in *Amos*, is missing in this case.

#### CONCLUSION

The reissue claims do not comply with the original patent requirement under § 251(a) and are therefore invalid. The district court correctly granted summary judgment of invalidity in favor of Forum.

#### AFFIRMED

#### COSTS

No costs.

---

<sup>2</sup> Similarly, in *Revolution Eyewear, Inc. v. Aspex Eyewear, Inc.*, we held that the challenged reissue claim complied with § 251 because there was no dispute that the figures of the original patent “depicted each element claimed” in the reissue claim. 563 F.3d 1358, 1366–67 (Fed. Cir. 2009) (citing *Amos*, 953 F.2d at 618).